



W2190 MULTI-PURPOSE INDICATOR
Calibration Manual

Manual reference: 55M2190GCE REV. B

For Sales and Support Contact

Crane Warning Systems Atlanta
1-877-672-2951 Toll Free
1-678-261-1438 Fax
www.craneindicators.com
sales@craneindicators.com

1. INTRODUCTION

1.1 System

The Wylie W2190 Multi-purpose Indicator can be a load, load and angle, load and length or a load and wind speed indicator. Anti-Two-Block condition is also monitored in any of these indicator configurations. The system can also be set with limits on load or on the optional input by the operator in order to produce a warning signal when required. **Only one option can be selected when ordering the system, this option can only be configured at the factory.**

1.2 Intelligent System

The system is “microprocessor based”, meaning that there is a computer inside the box with operating software. This software has two parts. Each has a distinct mode allowing different functions, the normal operating mode and the calibration mode.

The normal mode is the normal operating status of the unit when turned on. It is the only mode the operator should need for operating the system. In this mode the operator will be able to read the hook load and load limit, and set load and other limits, the hoist and the parts of lines.

The calibration mode allows for calibration of the sensors, and pressing a push button on the CPU Board is used to gain access to calibration routines and other variables. No other equipment is necessary to calibrate the system.

1.3 Adaptability

The system is designed to fit any lattice or telescopic boom crane with 1 or 2 hoists.

Thus its components can vary substantially from one machine to another.

The heart of the W2190 is the display unit. This box contains all electronic components required to convert sensor signals into the required information for the operator.

The other components are the load, angle, length or wind speed sensor depending on which option has been selected plus the Anti-Two-Block switches. All the above are connected to the display unit to provide basic data. There are many types of dynamometers and dead end load sensors, and two types of Anti-Two-Block switches.

The sensor choice depends on the type of crane, the required accuracy, the dismantling facility and the budget of the customer. It is also sometimes necessary in certain situations to use amplifiers between the sensors and the display unit. This will not change the accuracy of the system but will prevent radio interference and loss of signal when it is necessary to use connectors, slip rings or long cable. Junction boxes are also sometimes used to reduce the amount of wiring going to the display box.

2. HOW THE INDICATOR WORKS

2.1 Load sensor

Three sheave dynamometer

The dynamometer is a hoist line load sensor. It consists of a load cell in the middle sheave of a three-sheave arrangement. The three sheaves are positioned in a way that deflects the hoist line by a few degrees. When tensioned, the hoist line tends to straighten. This applies a force on the middle sheave and the load cell. The force is proportional to the hoist line tension. The hoist line tension is also proportional to the hook load (except for sheave friction).

Dead load sensor

This hoist line sensor consists of a load link installed on the dead hoist line attachment to the boom. Only even parts of line can be used, and for a telescopic crane a reeling drum is required to carry the signal back to the display.

How the load cell works

All load sensors work according to the same principle. The load cell operates on the basis of a wheatstone bridge. This means that four variable resistors of equal value are bonded to the weakest part of the load cell. When a load is applied, it changes the value of the resistors in opposite directions causing a voltage variation on the output wires. The voltage variation is in the order of thousandths of volts. Since the voltage output is so small, radio interference and wire resistance between the load cell and the control unit may influence it. This is why in some cases; an amplifier is necessary to ensure good transmission of the signal.

2.2 Amplifier

The amplifier is used when the distance between the load cell and the control unit exceeds 50 feet. Beyond this distance, radio waves and wire internal resistance may noticeably influence the load cell signal. The amplifier is also used when the signal wires of the load sensor must go through a slip ring.

The amplifier amplifies the load cell millivolt output into a 0-5 Volt signal, and then in a second stage, it converts the signal into a 4-20 mA output. The signal is then no longer sensitive to radio interference, internal wire resistance or internal wire or slip ring resistance.

2.3 Angle sensor

Pendulum type

The pendulum type is basically a high precision one-turn pot driven by a heavy pendulum. The pendulum will keep the pot's knob pointing toward the ground regardless of the angle of the boom. The resulting voltage output from the pot is proportional to the angle of the boom.

Liquid type

The liquid type angle sensor consists of two electrodes with a semi-conductor liquid in between. The electrodes send pulses through the liquid, which has a capacitive property. When the electrodes are fully immersed, the capacity is at its highest. As the boom angle changes, less electrode surface is in the liquid causing a small capacity. An internal circuit converts the pulse output to an analog output almost identical to the pendulum type signal.

2.4 Anti-two-block switch

The Anti-Two-Block switch is a spring-loaded switch. It is attached to the boom tip on one end and to a chain leading to a weight assembled around the hoist line at the other end. When the hook block lifts the weight, the switch becomes disengaged and the signal is cut.

2.5 Display box

The display includes both the operator display panel and the processing unit where the sensor signals are read and computed to determine the load. The results are then displayed to the operator using a liquid crystal display screen and indication lights. The display is composed of two sections:

The W2190 input/output board (I/O Board)

The input board includes all the wire connections. On this board, the signals are conditioned to be legible for the processor. The supply voltage is reduced from an input range of 11 to 28 VDC to 5 VDC to supply both the processor and the sensors.

The reduced voltages are sent up to the CPU board via a connector and colored wires. It can be unplugged by pulling gently downward on the colored wires.

The processed signals from the sensors are sent up to the CPU board via a flat ribbon connector. This connector can be unplugged when the power is OFF by pulling open the side clamps of the connector on the board.

On this board one fuse protects the supply voltage to the unit. Use a 1 amp 5X20mm for replacement.

There is a dry contact relay for both lockout and external alarm. It has a 2 amp on 24 VDC rating. It is used to control a slave relay. The terminals available are common, normally open and normally closed.

There is a serial communication port RS 232 on the terminal strip identified as TX, RX. This port is for future use.

Load cell sensor signals can be supplied to the board in the form of millivolts (direct load cell output) and current 4-20 ma. When the supply is in the form of current, the Dip Switch must be set. Refer to the amplifier section 3.2 **W2190 I/O Board**

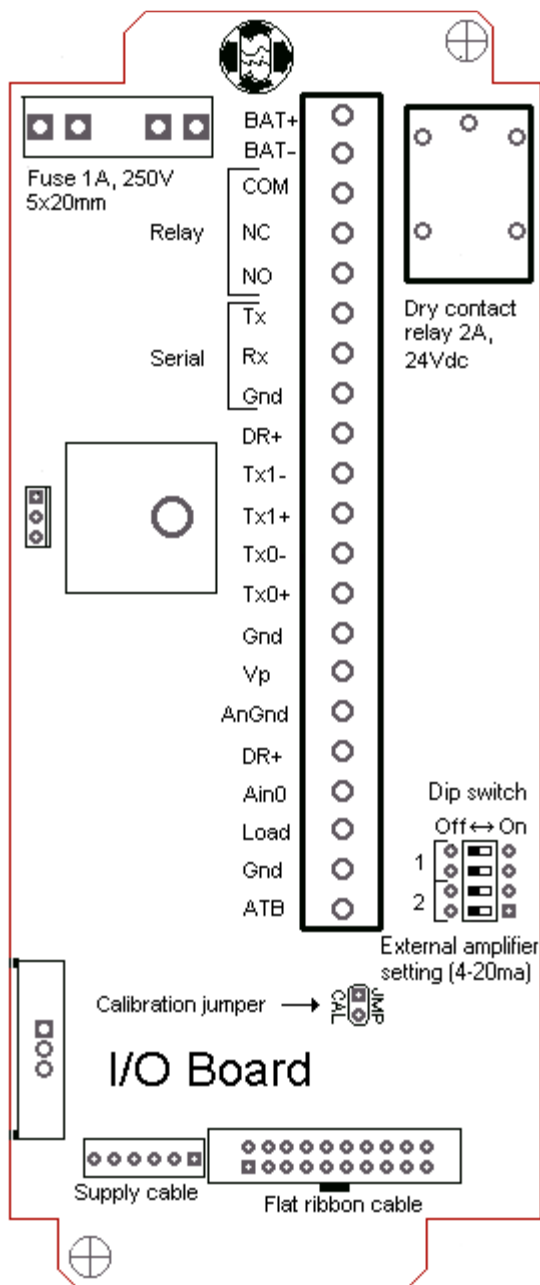

Connexion Description

- BATT+: Power Supply (+) (10 –28Vdc)
- BATT- : Power Supply (-)
- COM : Common Contact
- NC : Normally Close Contact
- NO : Normally Open Contact
- TX : Not used
- RX : Not Used
- GND : Not Used
- DR+ : Supply (+) for Load Sensor
- TX1- : Negative Signal of the Load Sensor on Aux Hoist
- TX1+ : Positive Signal of the Load Sensor on Aux Hoist
- TX0- : Negative Signal of the Load Sensor on Main Hoist
- TX0+ : Positive Signal of the Load Sensor on Main Hoist
- GND : Supply (-) for Load Sensor
- VP : Supply (+) to External Amplifier
- ANGND: Supply (-) for Optional Sensor (Angle, length or wind speed)
- DR+ : Supply (+) for Optional Sensor (Angle, length or wind speed)
- AIN0 : Analog input for Optional Sensor (Angle, length or wind speed)
- LOAD : Not Used
- GND : Power Supply (-) to External Amplifier or ATB signal ground
- ATB : Anti-Two-Block signal

The W2190 CPU board

The Central Processing Unit board reads all the sensor signals. A multiplexed amplifier is situated on the top left of the board which conditions the load cell input. This board can multiplex 2 load cell signals. Using the stored calibration data, the CPU converts the signals into information for hook load. The CPU also compares the information with the set limits entered by the operator. The CPU will finally trigger the alarms and lockout output if a limit is reached or if a Two-Block situation is sensed.

This board is the operator interface. It contains the alphanumeric Liquid Crystal Display (LCD), which provides such information as hook load, preset limits, failure messages, hoist used and parts of line. It contains the processing circuitry for the 4 button keypad.

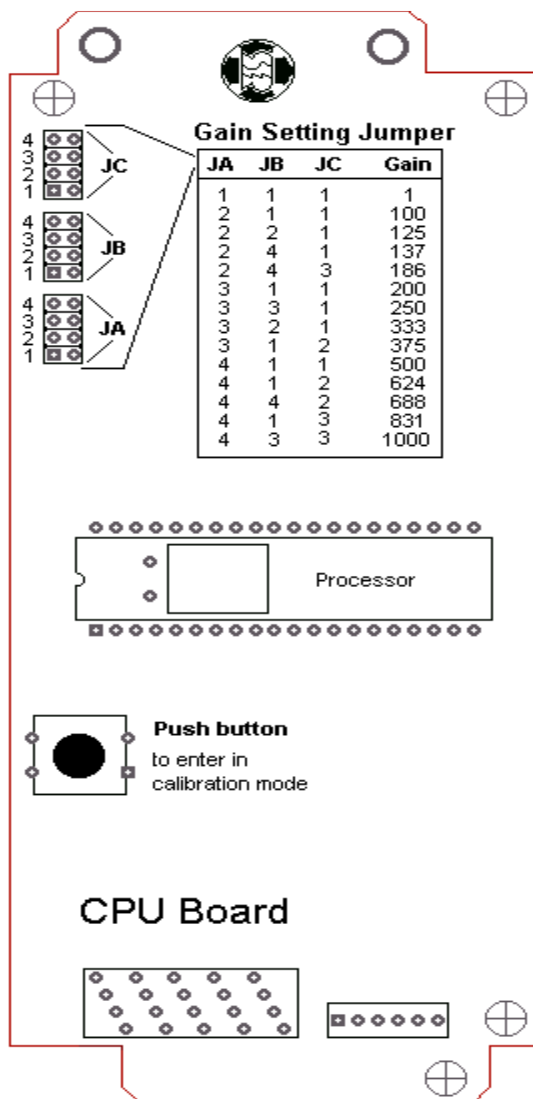

The gain setting is located on this board. Use 3 small jumpers to configure it. Default value is 333.

Use the Push button located below the processor to enter in calibration when the "CAL" jumper on I/O Board is removed.

3. INSTALLATION

3.1 Load sensor

Before and after installing, make sure that the load sensor operates properly at all boom angles and that the fleet angles are not exceeded. Make sure that the mounting bracket is strong enough to support the load sensor and the forces applied on it.

3.2 Amplifier

If an amplifier is needed, it is usually mounted on the dynamometer. If a multi-amplifier is supplied because of slip rings, mount the box on the turret part of the crane with the cable glands pointing downward. Wire according to the supplied drawing. Set the Dip Switch located on the I/O Board according to the following table:

SWITCH	Millivolt Output (NO Amplifier)	4 –20 ma Output (with Amplifier)
Dip Switch 1: Main	OFF	ON
Dip Switch 2: Main	OFF	ON
Dip Switch 3: Aux	OFF	ON
Dip Switch 4: Aux	OFF	ON

3.3 Anti-Two-Block switch

If two switches are to be used at the same time, make sure the proper switch or junction box is used at the boom tip.

If only one switch will be used and has to be moved from the main tip to the jib tip, it can be done using the same cable reel or with an extension wire. If using the cable reel, make sure the cable reel pay out will allow mounting to the end of the jib.

No wiring is needed, since a standard connector is supplied for the switch. If a junction box is used, wire according to the supplied drawing.

3.4 Display

The display should be located at the front of the cab, where it is readily visible from the operator's control position. Take care not to obscure any displays, control levers, switches or the operator's view of the load, etc. Leave sufficient room for the sensor wires to be fed from the bottom of the display.

If the unit is pre-wired with connectors, simply plug in the connectors. If the unit is not pre-wired, use the following instructions.

Loosen the four top screws and flip the cover over the box. Proceed gently in order not to damage the wires or the keypad.

Wire according to the supplied drawing Figure 3.5. Make sure all connections are done properly and completed before powering the system. When stripping wires, do not drop any wire ends or debris in the box.

All wire shields should be grounded to the cable glands of the display box only. Follow Figure 3.7. Fold the shield over the rubber sleeve. Use the brass ring for 2,3 and 4 lead wires.

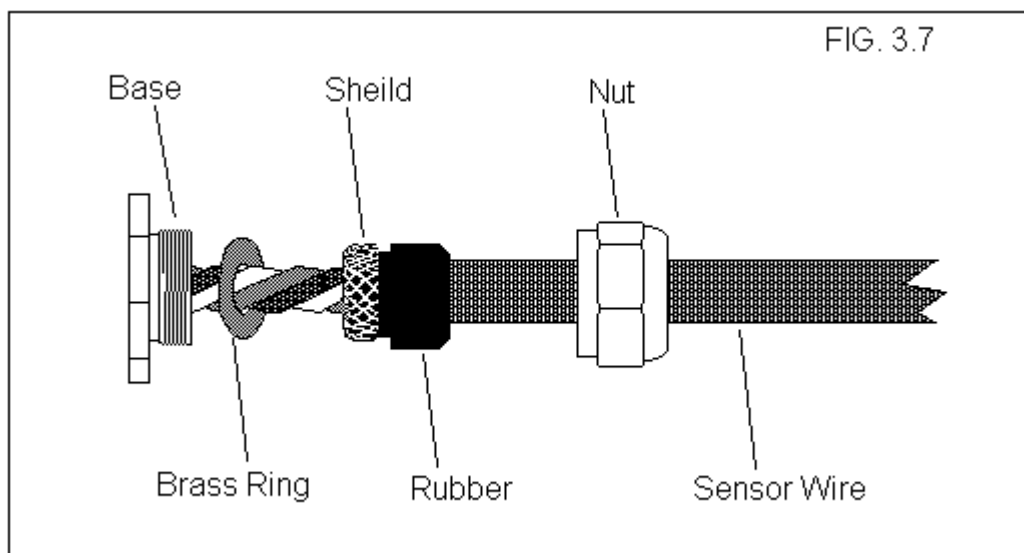

Power supply must be from 11 to 28 Volts DC only. If not available, an external power supply to convert to 12 Volts DC is required. Power lead must be able to sustain a minimum of 11 Volts with a current of 5 amps if the unit is connected to a lockout device.

Lockout wires should not be subjected to more than 2 amps on the internal relay. No wires should be routed near a radio antenna. All wires must be shielded. All wires must be fed away from mechanical parts, keep a minimum bending radii of two inches when static and 4 inches when moving.

Fig. 3.5: W2190 System Connection

This system connection diagram is for reference only, for more detail see wiring diagram provided with your system.

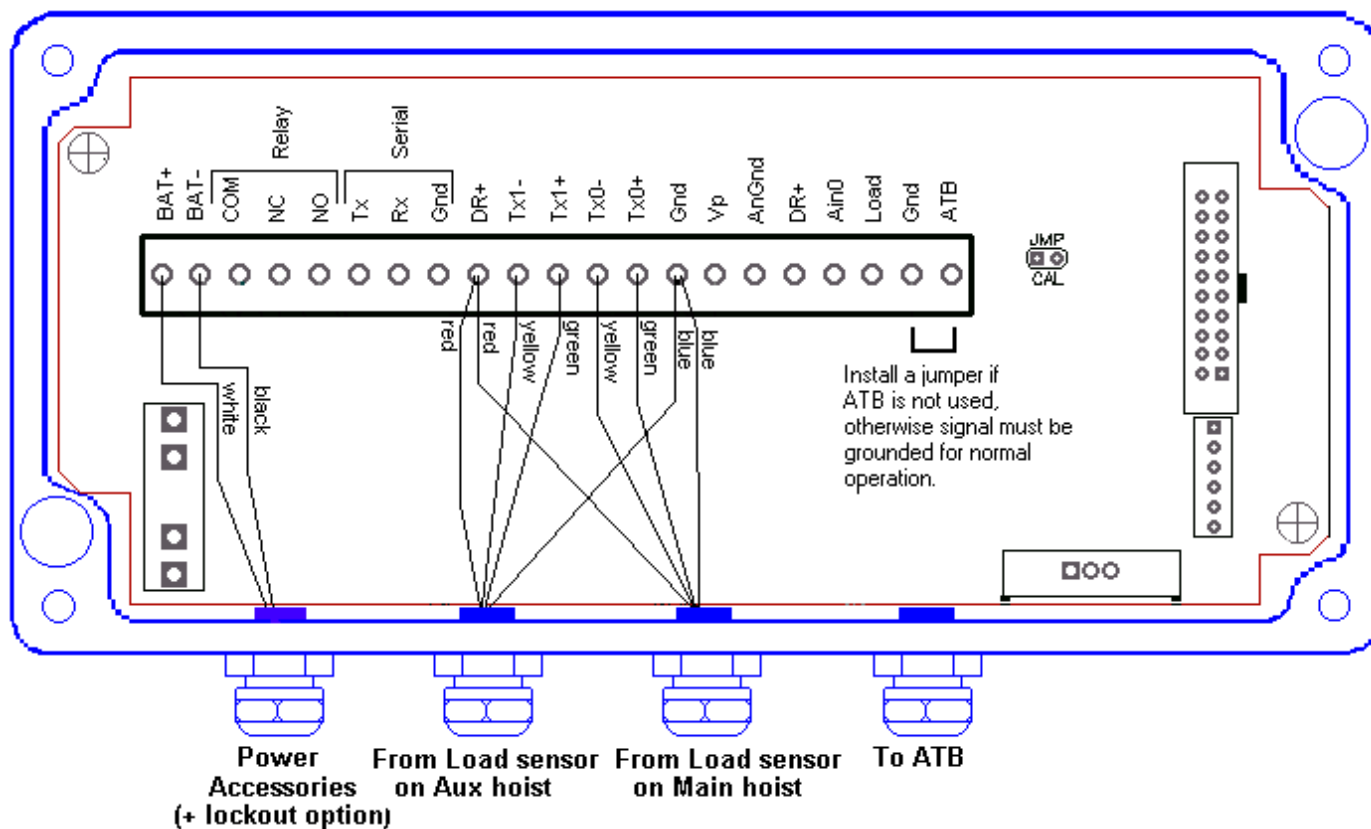

The lockout connection is according to your lockout configuration. Normal operation without ATB alarm gives a relay status of COM-NO. When an ATB condition is detected, the relay status will change for COM-NC.

The ATB signal is a Pull-Up signal; during normal operation the signal must be grounded. When an ATB condition occurs, the Ground to ATB Signal should be open. If the ATB is not used, you must install a jumper between ATB and GND.

3.5 Angle sensor option

Refer to installation drawing provided with your system

3.6 Length sensor option

Refer to installation drawing provided with your system

3.7 Wind speed sensor option

Refer to installation drawing provided with your system

4. Calibration for W2190

The calibration section will guide the technician and explain the procedures to follow, in order to rapidly and efficiently calibrate the crane and the system.

The calibration of the sensors is performed using software by entering data using the display's keypad. The only exception is that the amplifier jumpers are set manually.

Necessary Calibrating Tools	Test load that produces a line pull of approximately 90% of line pull. Each test load weight must be known accurately to within $\pm 1\%$.
Necessary Calibration Information	The rated line pull of each hoist line. The maximum number of parts of lines. The weight of each block, slings and attachment used for calibration. The hoist line weight per feet.

4.1 Preparation

Rig the main hoist line with minimum parts of line; two, three or four parts is acceptable. If the hoist line friction is high, the calibration will be less accurate with four than three parts of line. It is very important that the block hangs straight and directly below the head block.

Find a test load that represents maximum line pull when lifted by the main hoist. Reeve with one, two, three or four parts of lines as discussed in the above paragraph. Tested load weight must be known with $\pm 1\%$ accuracy.

Repeat this procedure with all other hoist lines.

4.2 General Procedure

General calibration data will be entered from the system's keyboard.

Before you start calibration, the sensors need to be verified for good working order. This is done using the calibration mode.

Calibrate main hoist line and the auxiliary hoist line, using test loads close to maximum line pull with minimum parts of lines.

4.2.1 System Initialization

When each sensor has been verified for its full functionality the system can be initialized in order to start the calibration procedure. This will obliterate all calibration data from the memory bank, and therefore **should be done only when a system is FULLY re-calibrated, do not perform a system initialization if you have the wind speed option otherwise pre-calibration data will be lost.** System initialization may also be required if a previous calibration was not properly done.

To perform a system initialization:

Press and hold buttons #3 and #4 at the same time when the system is powered up.

4.3 CALIBRATION MODE

The calibration mode is a separate entity of the W2190 system. It is totally independent of the regular operating mode as if it were a different system. The purpose of the calibration mode is to calibrate the load sensor(s), and to set points. Calibration mode will use the bottom key definition on the keypad.

The calibration mode is accessed by a push button located on the CPU board. The exact procedures are described in the next section.

The calibration mode is organized in a linear sequence. A series of items will appear. The ROLL UP (#2) or ROLL DOWN (#4) button will allow you to scroll through these items. Once in the calibration menu it is possible to scroll and access any stage of the calibration.

You will find on the next page, an organizational chart that explains the sequence for calibration depending on the option available.

System without option (load only) sequence numbered 1 to 8:

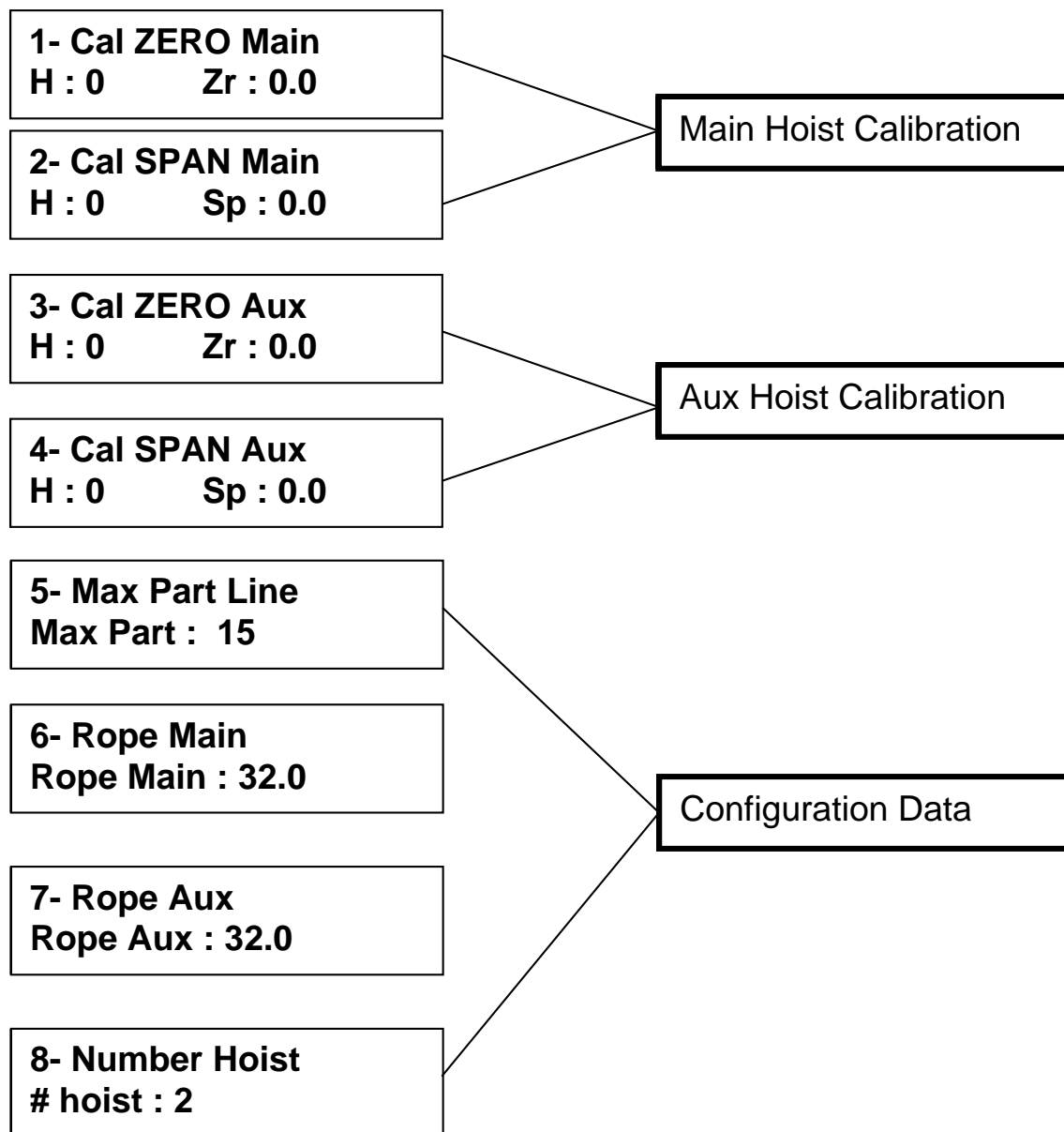

System with load and angle sensor option sequence numbered 1 to 10:

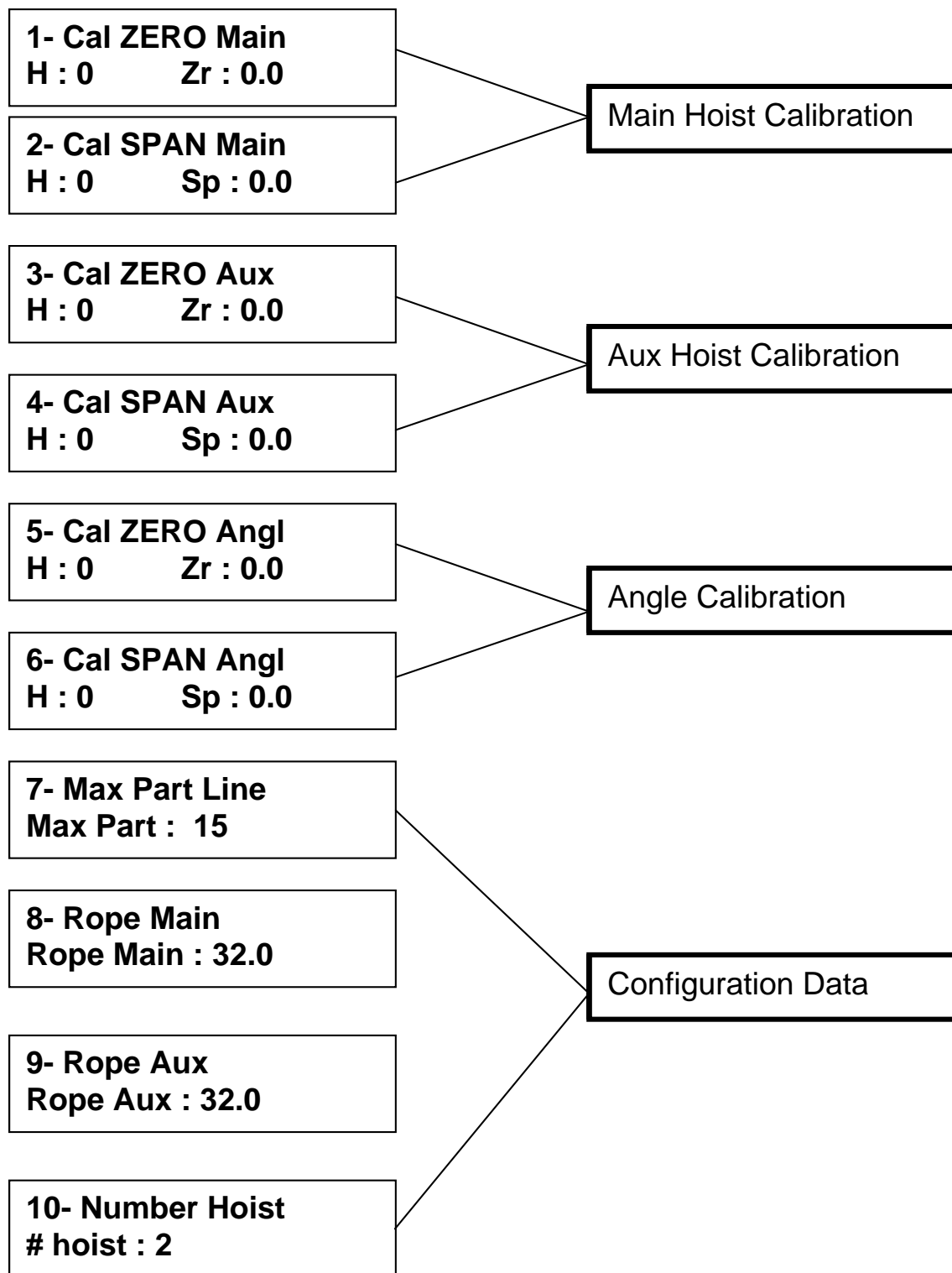

System with load and length sensor option sequence numbered 1 to 10:

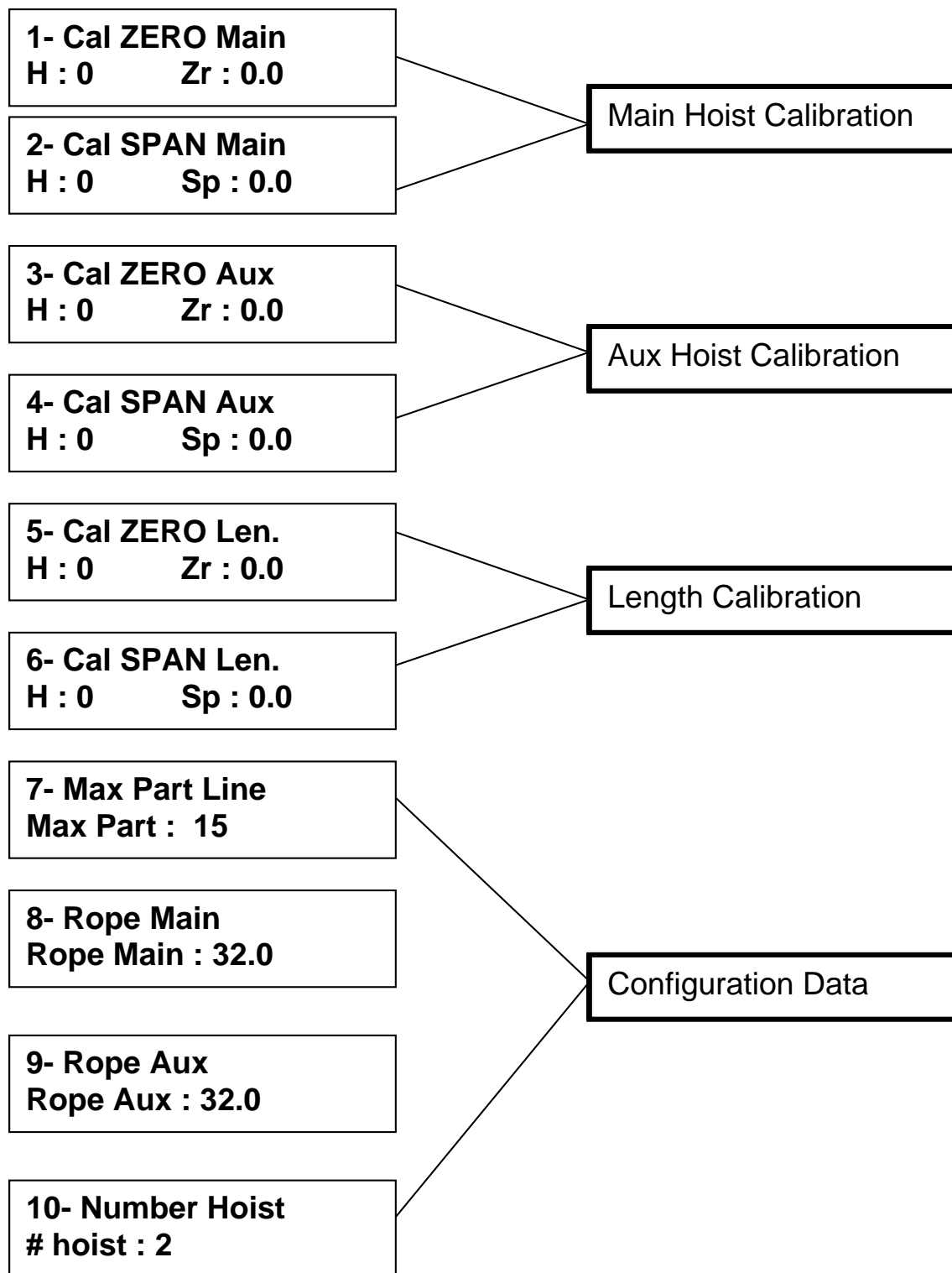

System with load and wind speed sensor option sequence numbered 1 to 10:

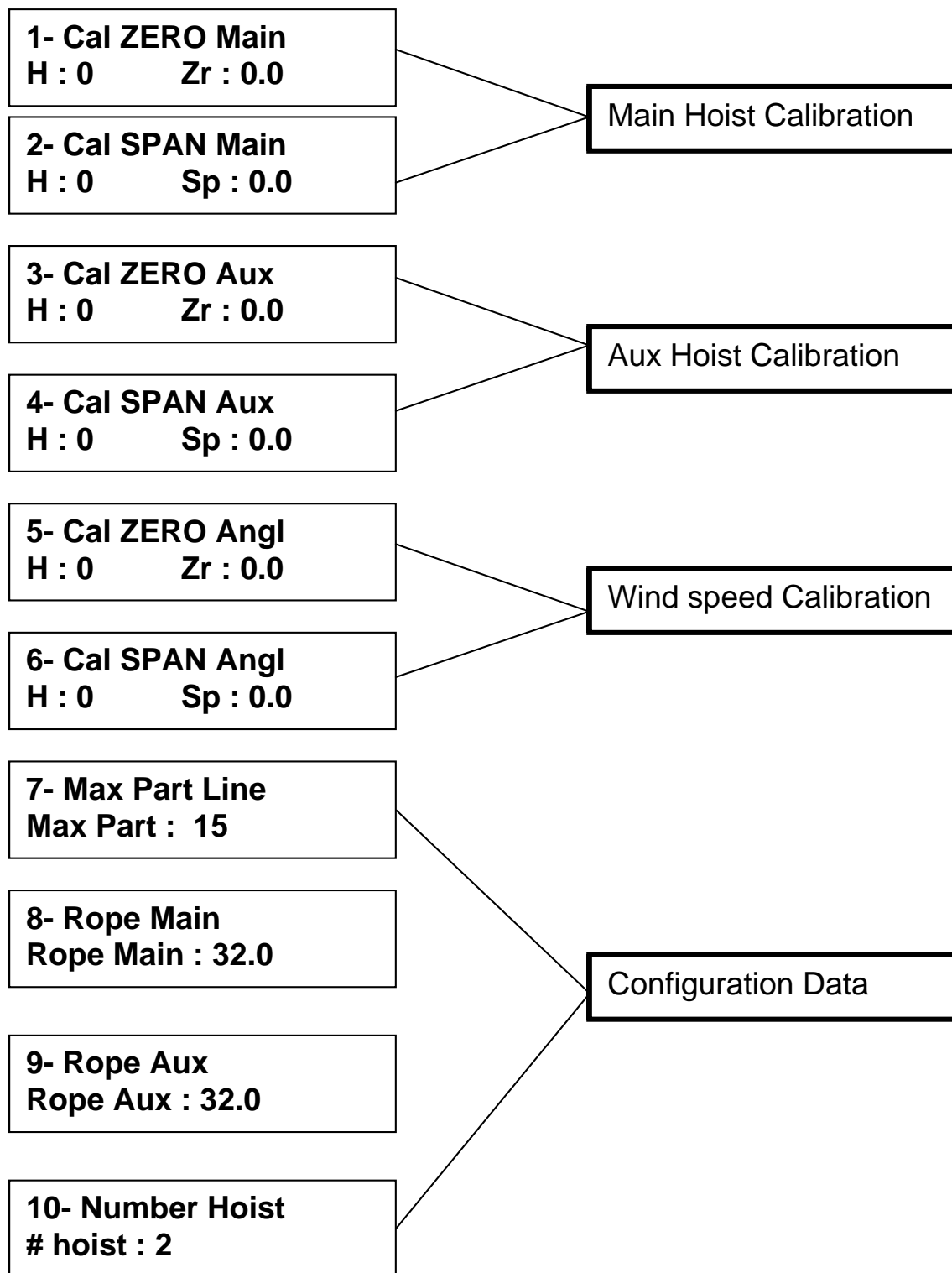

To enter into the calibration mode, unscrew the top cover to have access to the internal circuit. Turn the system on; wait until the system loads the basic screen display with load. Remove the "CAL" jumper located on the I/O Board. The system will alarm using the ATB light and buzzer. Press the push button located on the CPU Board.

The following menu will appear on the display:

1- Cal ZERO Main H : 0 Zr : 0.0

The system is now in the calibration mode.

By pressing the buttons DOWN (#4) or UP (#2), it is possible to scroll through the calibration menu.

4.5 System Configuration

Before beginning the hoist calibration, it is important to indicate to the system the number of hoists, the maximum line pull permitted per part of line and the maximum parts of line. Also if an external amplifier is not used, you will have to set the internal amplifier gain.

Number of HOISTS

System without option

8- Number Hoist # hoist : 2
--

System with option

10- Number Hoist # hoist : 2

To set the number of hoists, simply scroll all the way up to the menu 8-Number Hoist. Press the ENTER button (#3) to access the setting. The number of hoists will blink on the second line. Use the UP (#2) or DOWN (#4) button to increase or decrease the value. If you have both main and auxiliary hoists to calibrate, set the value to 2, otherwise set to 1 if you have only a main hoist to calibrate.

Maximum line pull on auxiliary line

System without option

7- Rope Aux Rope Aux : 32.0
--

System with option

9- Rope Aux Rope Aux : 32.0
--

Scroll down to menu 7- Rope Aux.

If you have an auxiliary hoist to calibrate, you have to set maximum line pull permitted per part of line on the auxiliary hoist according to the chart. This value will be used as the load limitation if it is lower than the limit capacity set by the operator. Press ENTER (#3) to access the setting. The value will blink on the second line. Use the UP (#2) or DOWN (#4) button to increase or decrease the value.

When you hold down any set button, the first digit (0.1 increment) will begin to change, after a while the second digit (1.0 increment) will change and finally the third digit (10.0 increment) will start to change.

Maximum line pull on Main line

System without option

6- Rope Main Rope Main : 32.0
--

System with option

8- Rope Main Rope Main : 32.0
--

Scroll down to menu 6- Rope Main.

This the maximum line pull permitted per part of line on the Main hoist according to the chart. This value will be used as the load limitation if it is lower than the limit capacity set by the operator. Press ENTER (#3) to access setting. The value will blink on the second line. Use the UP (#2) or DOWN (#4) button to increase or decrease the value.

When you hold down any set button, the first digit will change for a while, after the second digit will change and finally the third digit will start to change.

Maximum Parts of line

System without option

5- Max Part Line
Max Part : 15

System with option

7- Max Part Line
Max Part : 15

Scroll down to menu 7- Max Part Line.

Set the maximum number of parts of lines. This will apply to all hoists. To set this value, follow the same procedure as for the maximum line pull.

4.6 Return to normal operating mode for hoist setting

Choosing a hoist to calibrate must be done in the normal operating mode.

You are able to return to the normal operating mode at any time. Simply press the button ESC (#1), the system will automatically return to the operating mode. Before returning to the normal mode the “CAL” jumper must be replaced, otherwise the system will alarm with ATB light and buzzer that the “CAL” jumper has not been replaced.

When in the normal operating mode, use the Hoist (#2) and Part (#4) button to select the hoist to be calibrated with the part of line that will be used. If the parts of line stays on one (1), the maximum parts of lines was not set in the MENU 5 – Max Part Line. Refer to that section before continuing.

4.7 Hoist Load Calibration

At this point, the Load Sensor is ready for calibration. Get the crane ready to lift the test load. The load should be near maximum line pull on the hoist line. The load sensor can be calibrated on any number of parts of lines. However, to avoid mixing hoist line friction and rope reading fluctuations, it is preferable to calibrate the hoist line on the fewest parts of line possible. Return to calibration mode, and refer to the section Enter Calibration mode.

4.8 Internal amplifier setting

To adjust the internal amplifier (used when no external amplifiers are installed), lift a load with the appropriate hoist providing around 90% of the maximum line pull. While in the calibration mode, check value “H” for Main or Auxiliary Hoist (depending on which hoist is selected). This value is available in Menu 1 and 2 for Main Hoist or 3 and 4 for Auxiliary Hoist. H is the value of the input signal in terms of “Bits”, it uses the value from the Analog to Digital converter with a raw resolution of 4096 increments (Bits).

The W2190 works with a signal range of 0 to 4095 Bits. For a Load Sensor with no load on the hook, H should read between 600 and 800 bits, and when lifting 90% of maximum line pull, H should read between 3200-3650 Bits. If this is not the case, correct the internal amplifier setting as described in the following table.

Gain Table

JA	JB	JC	GAIN
1	1	1	1
2	1	1	100
2	2	1	125
2	4	1	137
2	4	3	188
3	1	1	200
3	3	1	250
3	2	1	333 *
3	1	2	375
4	1	1	500
4	1	2	624
4	4	2	688
4	1	3	831
4	3	3	1000

*** Default Value**

If H is lower than 3200 bits, set the jumpers to the next highest level until the signal is above 3200 and below 3650 bits.

If H is above 3650 Bits, set the jumpers to the next lowest level until the signal is below 3650 and above 3200 bits.

A Load Sensor having a standard sensitivity of 1.6mv/V to 2mv/V, gain should be set normally at 333. This is the default value

100% line pull should not exceed 3750 Bits, because a signal fail will be indicated. The same gain will be used for main and auxiliary hoist.

4.9 MAIN HOIST LOAD CALIBRATION

Before beginning this section, make sure that all previous steps have been completed and understood.

1- Cal ZERO Main H : 0 Zr : 0.0

MAIN HOIST

You must lift a small load with the crane that will correspond to \pm 10% of crane maximum rated capacity. The weight of the hook block is usually sufficient. Scroll down to 1-Cal ZERO Main. Press ENTER. The value on the lower right corner (ZL) will blink. Use the set buttons (#2 or # 4) to enter the true value of the total hanging weight (hook block, slings, hoist line below boom tip) in thousands of pounds units (ex: weight of 1000 lbs enter 1.0). Press ENTER to confirm. Note this value.

2- Cal SPAN Main H : 0 Sp : 0.0

MAIN HOIST

Lift the test load (90% of crane maximum rated capacity), stop and then lower a few inches and stop smoothly. Scroll down to 2- Cal Span Main. (See Note 1) Press ENTER, the value on the lower right corner (SL) will blink. Use the set buttons (#2 or #4) to adjust the display for the true value of the hanging weight (load, slings, hook block, shackles, hoist line below boom tip) in thousands of pounds units (ex: 30,000 Lbs enter 30.0). Press ENTER to confirm. The value SL should now show the hanging weight.

Note 1:

The value may not be stable, (i.e. increasing and decreasing rapidly), wait for the value to be as small as possible and quickly press ENTER. This will reduce the adjustment time. It may take a few trials to get a reasonable value; you should be able to get an initial blinking value of less than 4000.0. To try again press ESC, then wait for the value to decrease and press ENTER.

Verification

Verify that the weight displayed is corresponding to the load suspended. (See Note 2) Hoist up and stop at least at 5 different heights. Lower and stop at least at 5 different heights. Hoist at constant speed. Lower at constant speed. Write the result on a record sheet.

The weight displayed must be between 100% and 110% of the true value of the test load in any state and height.

Deposit the test load on the ground. Verify the display of the weight of the hook block with no load. The value should be between 70% and 130% of the actual total weight including hoist line.

Note 2:

If readings are consistent but inaccurate, it is possible that a fluctuation or a movement of the load while calibrating may have caused a load increase or decrease when pressing ENTER. Return to the calibration mode and repeat menu, 1 - ZERO Main and 2 -SPAN Main. Repeat the procedure as many times as necessary until the hook load both with and without the calibration weight shows the proper accuracy as described above.

If load reading is inconsistent even with one part line when testing during hoisting and stop or when testing during lowering and stop, the hoist line may be unevenly worn or simply uneven. To correct the problem, change the hoist line or change the Load Sensor. Replace the Load Sensor either with a larger model size or double the Load Sensor capacity.

RECORD SHEET: MAIN HOIST WITH SMALL TEST LOAD

DATE:					
TOT. WEIGHT:					
BLOCK WEIG:					
PART LINES:					
TIP HEIGHT:					
HOIST & STOP					
HEIGHT1:					
HEIGHT2:					
HEIGHT3:					
LOWEST:					
HIGHEST:					
LOWER&STOP					
HEIGHT 1:					
HEIGHT2:					
HEIGHT3:					
LOWEST:					
HIGHEST:					
LOWERING					
AVERAG:					
LOWEST:					
HIGHEST:					
HOISTING					
AVERAG:					
LOWEST:					
HIGHEST:					

4.10 AUXILIARY HOIST CALIBRATION

Choosing the hoist to be calibrated must be done in the normal operating mode. When in the normal operating mode, use Hoist (#2) and Part (#4) button to set the hoist to be calibrated with the part of line that will be used. If the parts of line stays on one (1), the maximum parts of line was not set in the MENU 5 – Max Part Line. Refer to that section before continuing.

At this point, the Load Sensor is ready for calibration. Prepare the crane to lift the test load. The test load should provide close to the maximum line pull on the single hoist line.

3- Cal ZERO Aux H : 0 Zr : 0.0
--

AUX. HOIST

You must lift a small load with the crane that will correspond to $\pm 10\%$ of crane maximum rated capacity. The weight of the hook block is usually sufficient. Scroll down to 3-Cal ZERO Aux. Press ENTER. The value on the lower right corner (ZL) will blink. Use the set buttons (#2 or # 4) to enter the true value of the total hanging weight (hook block, slings, hoist line below boom tip) in thousands pounds units (ex: weight of 1000 lbs enter 1.0). Press ENTER to confirm. Note this value.

4- Cal SPAN Aux H : 0 Sp : 0.0
--

AUX. HOIST

Lift the test load (90% of crane maximum rated capacity), stop and then lower a few inches and stop smoothly. Scroll down to 4- Cal Span Main. (See Note 1) Press ENTER, the value on the lower right corner (SL) will blink. Use the set buttons (#2 or #4) to adjust the display to the true value of hanging weight (load, slings, hook block, shackles, hoist line below boom tip) in thousands pounds units (ex: 30,000 Lbs enter 30.0). Press ENTER to confirm. The value SL should now show the hanging weight.

Note 3:

The value may not be stable, (i.e. increasing and decreasing rapidly), wait for the value to be as small as possible and quickly press ENTER. This will reduce the adjustment time. It may take a few trials to get a reasonable value; you should be able to get an initial blinking value of less than 4000.0. To try again press ESC, then wait for the value to decrease and press ENTER.

Verification

Verify that the weight displayed is corresponding to the load suspended. (See Note 4) Hoist up and stop at least at 5 different heights. Hoist down and stop at least at 5 different heights. Hoist at constant speed. Lower at constant speed. Write the result on a record sheet.

The weight displayed must be between 100% and 110% of the actual test load in any state and height.

Check the display of weight with no test load on the hook block. The displayed load should be between 70% and 130% of the actual total weight including hook block and hoist line.

NOTE 4:

If readings are consistent but inaccurate, it is possible that a fluctuation or a movement of the test load while calibrating may have cause a load increase or decrease when pressing ENTER. Return to the calibration mode and repeat menu 3 - ZERO LOAD and 4 -SPAN LOAD. Repeat the procedure as many times as necessary until the hook load both with and without the test load, shows the proper accuracy as described above.

If load reading is inconsistent even with one part line when testing during hoisting and stop or when testing during lowering and stop, the hoist line may be unevenly worn or simply uneven. To correct the problem, change the hoist line or change the Load Sensor. Replace the Load Sensor either with a larger model size or double the Load Sensor capacity.

RECORD SHEET: AUXILIARY HOIST SMALL REEVING

DATE:					
TOT. WEIGHT:					
BALL WEIGH:					
PART LINES:					
TIP HEIGHT:					
HOIST & STOP					
HEIGHT1:					
HEIGHT2:					
HEIGHT3:					
LOWEST:					
HIGHEST:					
LOWER&STOP					
HEIGHT 1:					
HEIGHT2:					
HEIGHT3:					
LOWEST:					
HIGHEST:					
LOWERING					
AVERAG:					
LOWEST:					
HIGHEST:					
HOISTING					
AVERAG:					
LOWEST:					
HIGHEST:					

4.11 Angle Option Calibration

5- Cal ZERO Angl H : 0 Zr : 0.0

Scroll down to 5 - ZERO ANGLE.

Boom down to minimum angle accessible; ideally zero degrees (main boom parallel to ground). The display will show on the second line the signal in bits. Using an angle indicator measure the actual boom angle.

The important aspect of the display in bits is to verify if the signal is changing through the entire working area of the boom angle.

Press ENTER to start the blinking of the lower right value and use the UP (#2) or DOWN (#4) button to adjust the system angle to the angle given by the inclinometer; press ENTER to confirm.

6- Cal SPAN Angl H : 0 Sp : 0.0

Scroll down to 6 -SPAN ANGLE.

Boom up over 65 degrees (main boom referred to ground). The display will show on the lower left corner the signal in bits (Signal H). Using an angle indicator measure the actual boom angle.

Press ENTER to start the blinking of the lower right value and use the UP (#2) or DOWN (#4) button to adjust the system angle to the angle given by the inclinometer; press ENTER to confirm.

Note: The Angle calibration can be done before hoist calibration if it is more convenient for you.

4.12 Length Option Calibration

5- Cal ZERO Len. H : 0 Zr : 0.0

Scroll down to 5 - ZERO LENGTH.

Fully retract the boom to minimum length. The display will show on the second line the signal in bits. Using a measuring tape measure the actual boom length. (Center of boom pivot pin to center of tip sheave) in feet and tenths of feet.

The important aspect of the display in bits is to verify if the signal is changing through the entire working area of the boom length.

Press ENTER to start the blinking of the lower right value and use the UP (#2) or DOWN (#4) button to adjust the system length to the actual length; press ENTER to confirm.

6- Cal SPAN Len. H : 0 Sp : 0.0

Scroll down to 6 -SPAN LENGTH.

Fully extend the boom to the maximum length. The display will show on the lower left corner the signal in bits (Signal H). Using a measuring tape measure the actual boom length. (Center of boom pivot pin to center of tip sheave) in feet and tenths of feet.

Press ENTER to start the blinking of the lower right value and use the UP (#2) or DOWN (#4) button to adjust the system length to the actual length; press ENTER to confirm.

Note: The length calibration can be done before hoist calibration if it is more convenient for you.

4.12 Wind Speed Calibration

The wind speed is pre-calibrated at the factory, **do not perform a system initialization otherwise the pre-calibration will be lost.**