

Operator's Manual

R1020: Length Indicator

Crane Warning Systems
Atlanta
1-877-672-2951 Toll Free
1-678-261-1438 Fax
www.craneindicators.com
sales@craneindicators.com

***** Warning *****

This system must never be used, under any circumstances, as a substitute for the good judgment of a crane operator when carrying out approved crane operating procedures. Responsibility for the safe operation of the crane lies with the crane operator, and the indicator equipment will not necessarily prevent crane damage due to overloading and related causes.

The safe operation of the crane is the sole responsibility of the operator who must observe and obey all warnings and instructions supplied by **Rayco**, the crane manufacturer, and the relevant Safety Authorities.

Before operating a crane equipped with a **Rayco** system, the operator must carefully read the information in both this manual and the crane manufacturers operators manual to ensure that he/she fully understands the correct operating procedures and safety standards.

Correct functioning of the system depends upon routine daily inspection and any suspected faults or apparent damage should be immediately reported to the responsible authority **before** using the crane.

The information in this manual is subject to change without notice. Rayco shall not be liable for errors contained herein or for any damages in connection with the furnishing or use of this manual.

Remember - The key to good performance of any piece of equipment is the efficiency of those who use it.

Table of Contents

Warning2

Introduction4

General layout5

Operating Procedures6

Installing the control box7

Introduction

The Rayco R1000 Series is a universal systems that was designed for custom applications. It is not a micro-processor based system nor a complicated system to use. On the contrary this system is easy to install and user friendly. The control box may be mounted vertically or horizontally, displays numbers ranging from -199.9 to 199.9, is equipped with a illuminated display for night viewing and most of all no programming is required. Although this reduces the versatility of the system, it simplifies its applications. Without having to program or perform any special modifications, this system has several uses. It may be utilized as:

- an overload
- a scale
- a length indicator
- an angle indicator
- a load indicator
- a level indicator, etc..

This system also has other features allowing it to perform more complex and sophisticated tasks.

The R1000 is an electronic instrument capable of monitoring and displaying an electrical linear change. This linear change can come from a sensor converting a physical change into an electrical one. When the limits of that change are the only concern, linearity is irrelevant.

The R1000 can be equipped with an alarm card which displays the following:

- a supply power condition light turning red or green according to the state of the input voltage
- a green light showing good status condition of the input
- a red light showing the digital input status
- a buzzer working in parallel with the alarm light.

When a limit has been reached, the R1000 will trigger a relay with both a normally closed and a normally opened connection. It can be used to stop or start a certain action in the event of an alarm.

The R1000 can also read two black and white inputs. The first input triggers the alarm instantly by bypassing the analog input. It can be used with a limit switch when a certain state overrides the analog status or to receive the relay output from another R1000 when mounted in series. The second input, available on a special alarm card, bypasses the system and neutralizes the relay output. It can be used as an emergency bypass of the relay output or with a limit switch if the status of the sensor is irrelevant at a certain point.

The R1000 also has a keyboard card allowing manual setting of limits and display of limits if the display card is present. The keyboard can also be used to control the tare when the system is used as a scale. A fine control is available with the addition of a potentiometer.

General Layout

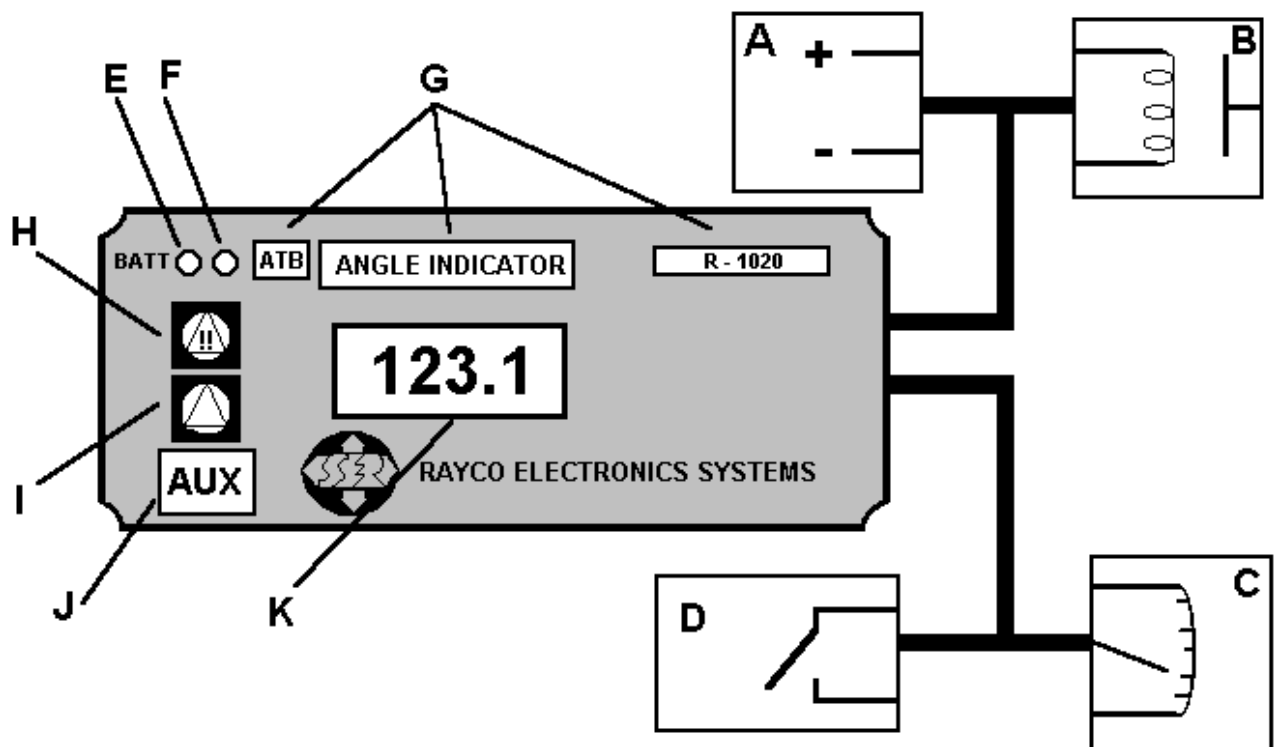

A: Supply wires compatible from 10 Vdc to 28 Vdc

B: Relay output 5 A NC and NO can activate a valve, a light or a relay

C: Analog sensor input 0-5 V, 4-20mA or 0-5 to 0-50 mV. Available supply for sensor is 5.00 V or original supply

D: Digital or black and white inputs

E: Power supply status:

- Light is off: less than 9V is being supplied therefore system will not operate correctly
- Light is red: receiving 9 to 11V power supply is running low
- Light is green: receiving 11 to 28V therefore system receiving correct power supply

F: Status of digital input #1 (usually the A2B)

- off: circuit is closed
- red: circuit is open

G: Customized label

H: Red visual alarm

I: Green good status visual indicator

J: Digital input #2, bypass button. May be deactivated

K: Numerical display of analog sensor value: from -199.9 to 199.9

Operating Procedures

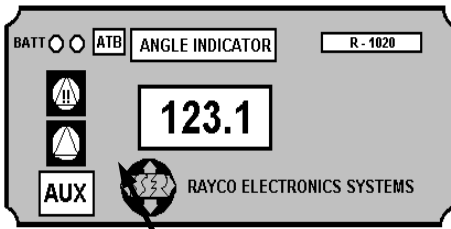

GREEN ON

The purpose of the R1020 is to display a numerical value corresponding to a change. Therefore, if the system is working properly, the operator does not have to do anything other than consulting the numerical display for its machine operating procedures.

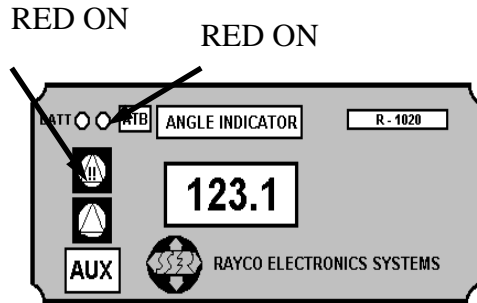

RED ON

RED ON

The R1020 also has the digital input which can be used to monitor an end of travel warning. If the digital input is cut off or the switch is turned off (opened); the system will display two red warning alarms and an audible alarm. The first one is the large triangular warning light which indicates that the relay output is activated. This means that

if a lock out device is installed, certain motions would be cut until the situation is reversed. The second warning light is the small top right hand light. it indicates that the source alarm comes from the digital input. The operator maneuver to return to the normal operating mode.

of the must

If the lock out relay output blocks all maneuvers; the operator can press the « AUX » button to temporarily bypass the lock out and return to the normal operating mode.

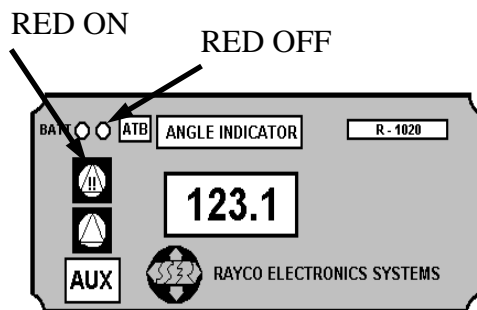

RED ON

RED OFF

If the large triangular warning light illuminates, the buzzer sounds and the small digital input light is off, the system indicates that either the machine is in abnormal situation or that it has failed. Therefore the operator cannot rely on the system until the green light reappears.

Installing the Control Box

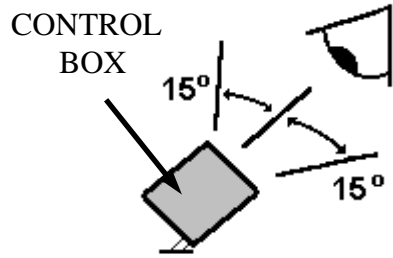

Place the control near the operator and bolt it onto the machine. Make sure the control box points directly towards the operator so that the display will be easily visual by the operator. Remain within $\pm 15^\circ$ from both axes.

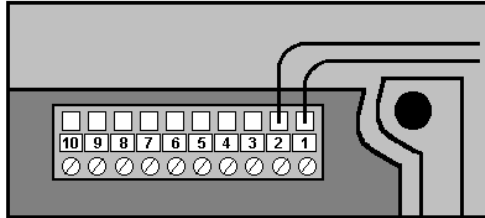

Feed the junction cable (18-3) through a collar and connect the wires as follows:

- red wire to terminal 1(positive)
- blue wire to terminal 2(negative)

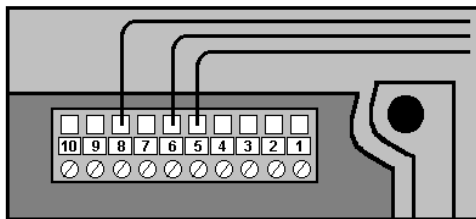

Bring angle sensor wire to the control unit and feed through the second collar. Connect the wires as follows:

- positive to terminal 5(Red)
- length sensor to terminal 6(Green)
- negative to terminal 8(Blue)

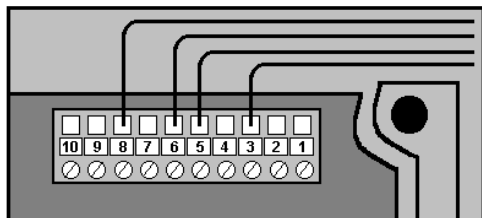

If an A2B system is also equipped with the control box then connect the wires as follows:

- ground A2B signal to terminal 3(Yellow)
- positive to terminal 5(Red)
- length sensor to terminal 6(Green)
- negative to terminal 8(Blue)

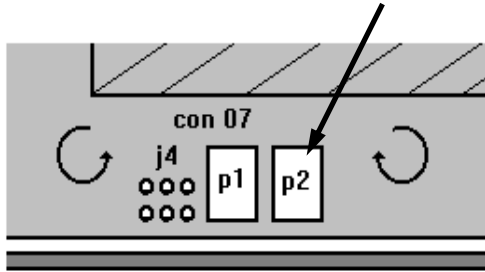

Retract the boom to the minimum. Turn potentiometer #2 until the display shows zero.

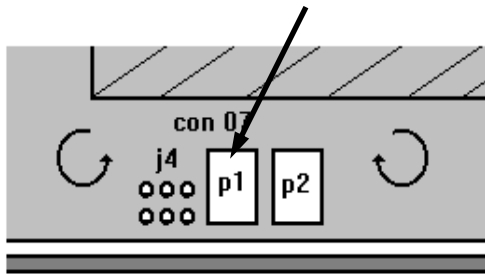

Extend the boom to at least 2/3 of its full length. Measure the length extended (not the total boom length) and turn potentiometer #1 until this value is exactly reached.

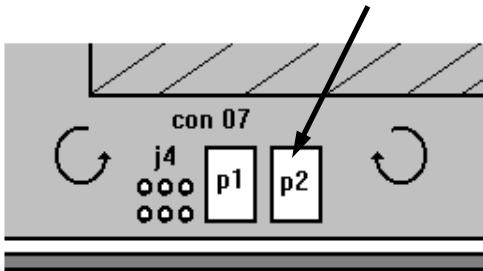

Measure the total boom length and turn potentiometer #2 until the numerical display shows that length.

Repeat the exercise of retracting and extending the boom, and re-calibrate if necessary.

Test the limits according to the operating procedures.

Close the control box.

Tighten all collars to ensure water resistance. Do not over tighten.

Test lock out.